

Equal Coupling

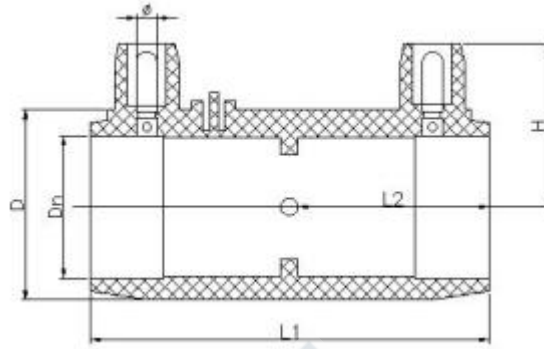

SIZE (mm)	Dn (Normal Diameter)	D (Max. OD)	L2 (Insertion Depth)	L1 (Total Length)
S20×20	20	30	42	88
S25×25	25	30	43	88
S32×32	32	30	44	92
S40×40	40	48	51	105
S50×50	50	60	52	109
S63×63	63	76	54	111
S75×75	75	90	61	126
S90×90	90	108	74	153
S110×110	110	131	85	170
S125×125	125	149	95	191
S140×140	140	166	107	223
S160×160	160	190	101	214
S200×200	200	238	133	276
S250×250	250	297	126	260
S315×315	315	373	114	236
S355×355	355	421	137	275
S400×400	400	474	150	302
S450×450	450	533	165	328
S500×500	500	592	180	367
S560×560	560	663	194	395
S630×630	630	746	219	439

Reducer

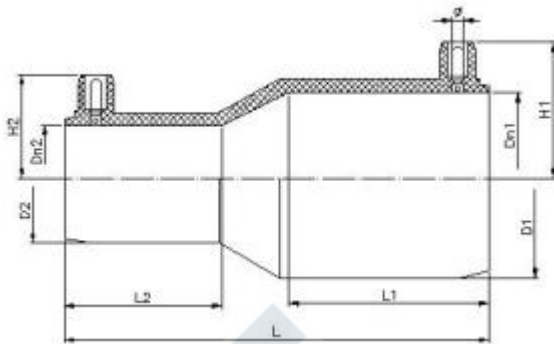

Size (mm)	Dn (Normal Dia)	Insertion Depth		Max. OD		L (Total Length)
		L1	L2	D1	D2	
S32×25	32×25	46	44	43	37	98
S40×32	40×32	51	49	54	44	108
S50×32	50×32	54	52	65	44	116
S50×40	50×40	54	46	65	53	114
S63×25	63×25	69	53	83	37	146
S63×32	63×32	63	56	83	44	131
S63×40	63×40	64	57	83	54	136
S63×50	63×50	69	55	84	66	136
S75×63	75×63	91	61	98	84	154
S90×50	90×50	74	62	115	68	160
S90×63	90×63	75	64	114	82	159
S90×75	90×75	75	72	114	98	160
S110×50	110×50	102	62	137	66	195
S110×63	110×63	102	79	137	83	208
S110×90	110×90	108	80	140	117	210
S125×110	125×110	109	91	157	140	220
S160×90	160×90	111	88	202	110	241
S160×110	160×110	112	91	202	135	237
S160×125	160×125	115	95	201	157	241
S200×160	200×160	126	105	241	193	258

Elbow 90°

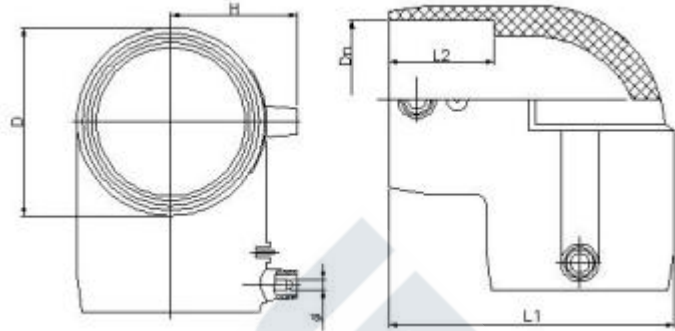

SIZE (mm)	Dn (Normal Diameter)	D (Max. OD)	L2 (Insertion Depth)	L1 (Total Length)
L20×90°	20	36	47	77
L25×90°	25	35	44	77
L32×90°	32	43	43	79
L40×90°	40	51	56	101
L50×90°	50	67	59	112
L63×90°	63	81	63	140
L75×90°	75	96	76	161
L90×90°	90	110	84	185
L110×90°	110	135	107	229
L125×90°	125	146	105	250
L140×90°	140	170	116	277
L160×90°	160	202	117	295
L200×90°	200	238	156	378
L250×90°	250	300	141	416
L315×90°	315	372	125	474
L355×90°	355	418	138	532
L400×90°	400	469	147	593
L450×90°	450	525	162	650
L500×90°	500	570	176	736

Equal Tee

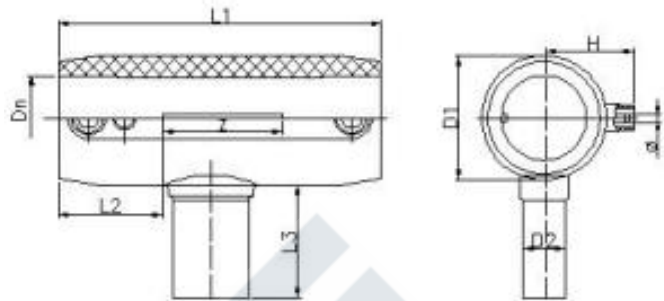

SIZE (mm)	Dn (Normal Dia.)	L2 (Insertion Depth)	D1 (Max. OD)	L1 (Total Length)	L3 (Branch Length)	D2 (Branch OD)
T25	25	42	38	105	43	25
T32	32	50	44	124	44	32
T40	40	54	54	145	48	40
T50	50	56	59	149	53	50
T63	63	62	85	174	54	63
T75	75	64	99	190	62	75
T90	90	85	116	246	77	90
T110	110	78	137	254	88	110
T125	125	95	158	294	93	125
T200	200	119	243	439	129	200
T250	250	121	298	465	128	250
T315	315	121	342	462	125	315
T400	400	151	473	627	159	400
T450	450	162	531	696	171	450
T500	500	180	593	771	192	500

Reducing Tee

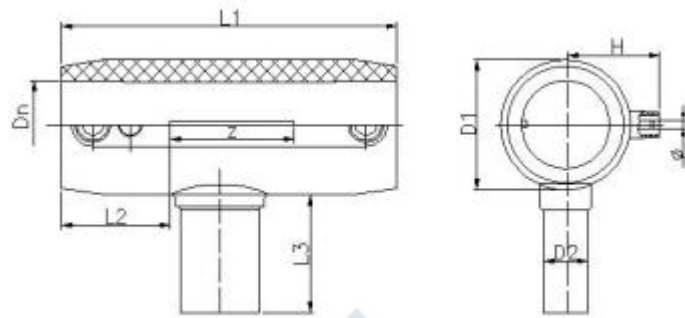

SIZE (mm)	Dn (Normal Dia.)	L2 (Insertion Depth)	D1 (Max. OD)	L1 (Total Length)	L3 (Branch Length)	D2 (Branch OD)
T63×20×63	63×20×63	56	84	155	41	20
T63×25×63	63×25×63	56	83	155	40	25
T63×32×63	63×32×63	56	83	155	38	32
T63×40×63	63×40×63	57	83	155	45	40
T63×50×63	63×50×63	61	83	173	50	50
T75×32×75	75×32×75	64	100	187	40	32
T75×40×75	75×40×75	66	99	188	43	40
T75×50×75	75×50×75	62	99	188	49	50
T75×63×75	75×63×75	64	99	187	55	63
T90×32×90	90×32×90	86	116	247	62	32
T90×40×90	90×40×90	86	115	247	66	40
T90×50×90	90×50×90	85	116	247	61	50
T90×63×90	90×63×90	85	115	248	69	63
T90×75×90	90×75×90	86	115	245	74	75
T110×32×110	110×32×110	84	137	245	51	32
T110×40×110	110×40×110	86	140	245	56	40
T110×50×110	110×50×110	86	138	244	61	50
T110×63×110	110×63×110	84	138	242	67	63
T110×75×110	110×75×110	85	137	243	75	75
T110×90×110	110×90×110	83	138	244	78	90
T125×110×125	125×110×125	97	156	294	91	110
T160×63×160	160×63×160	112	198	362	74	63

Reducing Tee

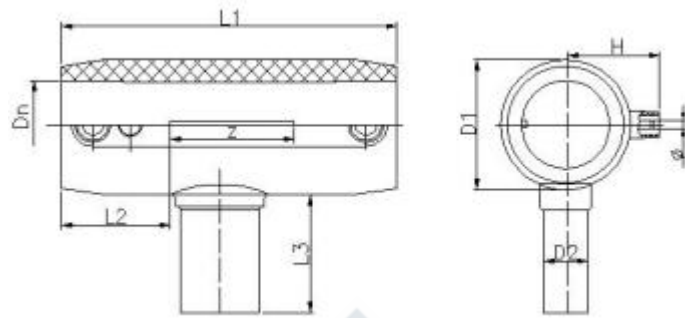

SIZE (mm)	Dn (Normal Dia.)	L2 (Insertion Depth)	D1 (Max. OD)	L1 (Total Length)	L3 (Branch Length)	D2 (Branch OD)
T160×75×160	160×75×160	113	201	365	82	75
T160×90×160	160×90×160	110	198	359	86	90
T160×110×160	160×110×160	112	200	362	98	110
T200×63×200	200×63×200	143	242	440	94	63
T200×75×200	200×75×200	141	243	436	71	75
T200×90×200	200×90×200	138	243	439	80	90
T200×110×200	200×110×200	132	243	440	95	110
T200×160×200	200×160×200	120	243	438	116	160
T250×90×250	250×90×250	123	302	468	87	90
T250×110×250	250×110×250	120	295	461	99	110
T250×160×250	250×160×250	119	299	458	104	160
T250×200×250	250×200×250	123	302	464	112	200
T315×110×315	315×110×315	134	381	515	108	110
T315×160×315	315×160×315	134	381	515	122	160
T315×200×315	315×200×315	134	381	515	128	200
T315×250×315	315×250×315	134	381	515	144	250
T400×110×400	400×110×400	152	478	633	109	110
T400×160×400	400×160×400	152	478	633	129	160
T400×200×400	400×200×400	152	478	633	133	200
T400×250×400	400×250×400	152	478	633	164	250
T400×315×400	400×315×400	152	478	633	166	315
T450×110×450	450×110×450	164	535	701	104	110

Reducing Tee

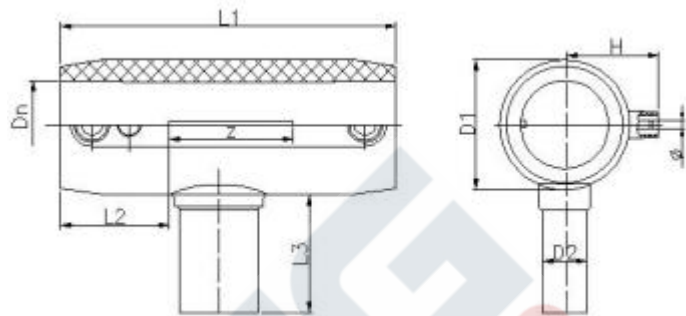

SIZE (mm)	Dn (Normal Dia.)	L2 (Insertion Depth)	D1 (Max. OD)	L1 (Total Length)	L3 (Branch Length)	D2 (Branch OD)
T450×160×450	450×160×450	164	535	701	124	160
T450×200×450	450×200×450	164	535	701	134	200
T450×250×450	450×250×450	164	535	701	164	250
T450×315×450	450×315×450	164	535	701	170	315
T450×400×450	450×400×450	164	535	701	186	400
T500×110×500	500×110×500	178	599	771	107	110
T500×200×500	500×200×500	178	599	771	137	200
T500×250×500	500×250×500	178	599	771	150	250
T500×315×500	500×315×500	178	599	771	166	315
T500×400×500	500×400×500	178	599	771	188	400